



Ceyear
www.ceyear.com

Ceyear Technologies Co., Ltd

No. 98 Xiangjiang Rd, Huangdao District, Qingdao City, Shandong Province, China
Tel: (+86 532) 86896691
Post Code: 266555
E-mail: sales@ceyear.com
This information is subject to change without notice.
Published in May, 2022
www.ceyear.com

Ceyear



Millimeter Wave and Terahertz Test System Overview

- Millimeter Wave and Terahertz Test System Overview
- Main Functions & Technical Specifications
- Test System Solutions

Ceyear Technologies Co., Ltd



Contents

Millimeter Wave and Terahertz Test System Overview

Main Functions & Technical Specifications

Main Functions

Technical Specifications

Test System Solutions

mm-wave and THz Vector Network Analysis System

Mm-wave and THz Signal Generation System

Mm-wave and THz Spectrum Analysis System

Mm-wave and THz Power Measurement System

Mm-wave and THz Antenna Test System

Mm-wave and THz RCS Test System

Mm-wave and THz Material Test System

About Us

Ceyear Technologies Co., Ltd has been committed to providing customers with precise, high quality electronic measurement instruments and services over the last 50 years.

Now we have become one of the largest manufacturers of electronic test and measurement equipment in the world. We supply electronic measurement instruments with frequency up to 1.1 THz, such as signal generators, signal analyzers, network analyzers, power meters and microwave components, which can be used for electronic test and measurement in aviation industry, material test and communications upgrading. We, as an important partner of electronic industry, network operators and public laboratory, provide comprehensive solutions on the basis of perfect products, including simulations and analysis of complex electromagnetic signal, construction and maintenance of optical fiber communication network, and establishment of general laboratory.

Millimeter Wave and Terahertz Test System Overview

Nowadays, mm-wave and terahertz technology has been widely used in radar, electronic interference, electronic reconnaissance, precision guidance, communications, inter-star satellite communications and other military electronics fields. In the civil field, mm-wave and terahertz technology has been applied to automotive collision-proof radar, remote sensing, astronomical observation, 6G communication system and other technical fields. The development and utilization of Millimeter Wave and Terahertz technology based on solving the testing and measurement challenges of the Millimeter Wave and Terahertz band. The Millimeter Wave and Terahertz test system developed and produced by Ceyear achieves high performance in many fields such as vector network analysis, signal generation, spectrum analysis, power measurement, antenna testing, radar cross-section (RCS) test and material electromagnetic parameter testing, etc.

Ceyear mm-wave and THz vector network analysis system is an important category of millimeter-wave terahertz test instruments, which is mainly used to test active/passive components S-parameters, electromagnetic material performance, antenna and radar cross-sections, etc. Ceyear millimeter-wave terahertz vector network analysis system can obtain the amplitude information, phase information and group delay characteristics of the network under test at the same time, and can meet the requirements of wideband, large dynamic range and high-speed real-time measurement, especially suitable for the test of active device S parameters. It is a necessary test instrument for the development of phased array technology.

Ceyear mm-wave and THz signal generation system consists of a millimeter-wave terahertz source extender module and a signal generator, which has the advantages of small size, easy to use, economical and efficient. This system can provide the same frequency resolution as the signal generator. And can also generate signal with reliable spectrum and power performance in a large dynamic range.

Ceyear mm-wave and THz spectrum analysis system consists of a frequency expander module and a

spectrum analyzer. This system provides advanced receiver performance, comprehensive measurement application functions and easy to use.

Ceyear mm-wave and THz diode Power Sensor has high detection speed and is easy to form a frequency sweep power measurement system that provides fast power measurement.

Ceyear mm-wave and THz antenna test system is mainly used on antenna performance parameters test in satellite, missile, radar, communication, navigation and other equipment, which can automatically test the direction map, side lobe level, gain, axis ratio, polarization isolation and other technical indicators. The system adopts the generalized, modular design idea. Based on Ceyear's new generation high-sensitivity beam receiver and multiple frequency extender modules, users can flexibly realize the testing needs of each millimeter wave frequency band. The system can meet the needs on conventional antenna, phased array antenna, DBF antenna, chip antenna and other Millimeter Wave and Terahertz antenna testing.

Ceyear mm-wave and THz RCS test system is mainly used in radar stealth performance testing and evaluation of aircraft, chariots, missiles, ships and other equipment. The system can support RCS precision test and evaluation, target strong scattering distribution imaging and diagnosis, target local scattering characteristic imaging analysis, target RCS characteristic reduction test and so on. Ceyear antenna test system and RCS test system have advantages of fast speed, high precision, high intelligence degree, complete parameters support, flexible configuration and so on. Besides testing equipment, Ceyear can further provide near/far field test solutions, chamber/outdoor site condition design, auxiliary structure selection (scanning frame, turntable, etc.) and full system integration services. Ceyear has full capability to perform real turnkey project.

Ceyear mm-wave and terahertz material electromagnetic parameters test system consists of vector network analyzers, test fixtures, test software,

etc. It can provide full-band material test ability up to 750GHz (1.1THz) via the frequency extender module. The system has high test accuracy, fast speed and flexible configuration, and can comprehensively test the parameters of complex permittivity, complex

permeability, loss, reflectivity, transmissivity and so on. It can also satisfy the testing needs of various material types, including solids, powders, fluids and semi-fluids, by configuring different test fixtures.

Main Functions & Technical Specifications

Main Functions

The millimeter-wave terahertz vector network analysis system can accurately and efficiently test parameters such as the amplitude, phase and group delay characteristics of the network under test.

The millimeter-wave terahertz source extender module extends the low-band signal input into the signal generator to the high frequency band, and forms a millimeter-wave terahertz signal generation system with the signal generator to achieve high-quality signal generation.

The millimeter-wave terahertz frequency extender module is used in conjunction with the spectrum analyzer to form a millimeter-wave terahertz spectrum analysis system. It can be used for spectrum measurement in a wide frequency band with large dynamic range, high sensitivity and high resolution. Multiple testing functions such as modulation performance, harmonic distortion, and third-order intercept, excitation response is supported. The mm-wave and terahertz Power Sensor and power meter form a power measurement system. The system has power, linear, temperature compensation function, using diode detection technology to realize high

speed frequency sweep measurement.

The millimeter-wave terahertz antenna test system has near-field test/far-field measurement configurations. It can perform direction map test, gain test, polarization test, data storage, data analysis, high-resolution diameter field diagnosis, array antenna channel consistency test and so on.

The mm-wave and terahertz RCS test system has 1D/2D/3D RCS imaging, far-field RCS value test, target subject local scattering characteristics rapid imaging, near-to-far field RCS extrapolation, frequency/time/angle domain measurement, hardware time domain gate control, RCS calibration and other functions.

The millimeter-wave terahertz material test system has a variety of test solutions such as coaxial transmission line method, waveguide transmission line method, free space method, resonant cavity method, probe method, bow frame method, etc. Comprehensive analysis can be made on the test items such as complex permittivity, complex permeability, loss angle, reflectivity and transmissivity.

Technical Specifications

Tab. 1 to Tab. 7 list technical specifications of Ceyear's mm-wave and THz frequency extender modules for Vector Network Analyzer, Signal Generator and Spectrum Analyzers.

Tab. 1 Mm-wave and THz VNA Frequency Extender Module Specifications

Model	3643K	3643NA	3643N	3643P	3643QA	3643Q	3643SA
Freq. Range (GHz)	40 to 60	50 to 75	60 to 90	75 to 110	90 to 140	110 to 170	140 to 220
Output Power (dBm)	Standard	≥ + 6	≥ + 5	≥ + 5	≥ + 5	≥ + 3	≥ -1
	Power Tunable Version (Electric tuning)	-	≥ + 5	≥ 0	≥ 0	-	-
Power Adjustment Range (dB)	-	≥ 25	≥ 25	≥ 25	-	-	-
System Dynamic Range (10Hz IFBW, dB)	≥ 100	≥ 100	≥ 100	≥ 100	≥ 100	≥ 100	≥ 100
	105 (Typ.)	105 (Typ.)	105 (Typ.)	105 (Typ.)	105 (Typ.)	105 (Typ.)	105 (Typ.)
Effective Directivity (dB)	≥ -35	≥ -35	≥ -35	≥ -35	≥ -34	≥ -34	≥ -30
Effective Load Match (dB)	≥ 0.12	≥ 0.12	≥ 0.12	≥ 0.12	≥ 0.15	≥ 0.15	≥ 0.2
Transmission Tracking(± dB)	≥ 0.12	≥ 0.12	≥ 0.12	≥ 0.12	≥ 0.15	≥ 0.15	≥ 0.2
Output Port	WR19	WR15	WR12	WR10	WR8.0	WR6.5	WR5.1
Dimensions (W×H×D, mm)	120×85×240						

Tab. 1 (Cont.) Mm-wave and THz VNA Frequency Extender Module Specification

Model	3643R	3643S	3643TA	3649B	3643U	3643V
Freq. Range (GHz)	170 to 260	220 to 325	260 to 400	325 to 500	500 to 750	750 to 1100
Output Power (dBm)	Standard	≥ -10	≥ -13	≥ -20	≥ -23	≥ -30
	Power Tunable Version (Electric tuning)	-	-	-	-	-
Power Adjustment Range (dB)	-	-	-	-	-	-
System Dynamic Range (10Hz IFBW, dB)	≥ 100	≥ 95	≥ 80	≥ 80	≥ 70	≥ 40
	105 (Typ.)	105 (Typ.)	100 (Typ.)	100 (Typ.)	-	50 (Typ.)
Effective Directivity (dB)	≤ -25	≤ -25	≤ -20	≤ -20	≤ -20	≤ -20
Effective Load Match (dB)	≤ -25	≤ -25	≤ -20	≤ -20	≤ -20	≤ -20
Reflection Tracking(± dB)	≤ 0.2	≤ 0.2	≤ 0.3	≤ 0.3	≤ 0.8	≤ 0.6
Transmission Tracking(± dB)	≤ 0.2	≤ 0.2	≤ 0.3	≤ 0.3	≤ 0.8	≤ 0.6
Output Port	WR4.3	WR3.4	WR2.8	WR2.2	WR1.5	WR1.0
Dimensions (W×H×D, mm)	120×85×240					

※ The dynamic range listed in Tab. 1 belongs to VNA frequency extender module. (Ratio between max. output power and min. measurable signal.)

Tab. 2 Mm-wave and THz Signal Source Extender Module Specifications

Model	82406	82401N	82406A	82401QA	82406B	82406C
Freq. Range (GHz)	50 to 75	220 to 325	260 to 400	325 to 500	500 to 750	750 to 1100
Output Power Range(dBm)	≥ +13	≥ -13	≥ -20	≥ -23	≥ -30	≥ -40
	16(typ.)	-	-	-	-	-
Amplitude Stabilization Option	Yes	-	-	-	-	-
Input Freq. Range (GHz)	12.5 to 18.75	≥ 95	≥ 80	≥ 80	≥ 70	≥ 40
Dimensions (W×H×D, mm)	120×85×240					
Power Source Input	15V Adapter					
RF Input Port	3.5mm (f)					
Output Port	WR15	WR12	WR10	WR8.0	WR6.5	WR5.1

Tab. 2 (Cont.) Mm-wave and THz Signal Source Extender Module Specifications

Model	82401SA	82406D	82401TA	82406E	82401U	82401V
Freq. Range (GHz)	170 to 260	220 to 325	260 to 400	325 to 500	500 to 750	750 to 1100
Output Power Range(dBm)	≥ -6	≥ -8	≥ -12	≥ -16	≥ -25	≥ -33
	0(typ.)	-3(typ.)	-6(typ.)	-10(typ.)	-23(typ.)	-25(typ.)
Amplitude Stabilization Option	NA	NA	NA	NA	NA	-
Input Freq. Range (GHz)	14.17 to 21.67	12.2 to 18.06	14.44 to 22.22	9.02 to 13.89	9.25 to 13.89	10.41 to 15.28
Dimensions (W×H×D, mm)	120×85×240			120×89×240		
Power Source Input	15V Adapter					
RF Input Port	3.5mm (f)					
Output Port	WR4.3	WR3.4	WR2.8	WR2.2	WR1.5	WR1.0

Tab. 3 Mm-wave and THz Spectrum Analyzer Frequency Extender Module Specifications

Model	82407NA	82407NC	82407PA	82407QA	82407QB	82407RA	82407SA
Freq. Range (GHz)	50~75	60~90	75~110	90~140	110~170	140~220	170~260
Num. of Harmonics	6	6	9	9	12	18	18
Freq. Conversion Loss (max, dB)	12	12	12	14	14	16	18
Noise Level (dBm/Hz)	-150	-150	-150	-150	-150	-145	-145
LO Power Range (dBm)	8 to 12	8 to 12	8 to 12	8 to 12	8 to 12	8 to 12	8 to 12
Max. RF Input Level (dBm)	0/10	0/10	0/10	0/10	0/10	-10/10	-10/10
Input Port Interface	WR15	WR12	WR10	WR8.0	WR6.5	WR5.1	WR4.3
Dimensions(W×H×D, mm)	≤120×85×240						
Model	82407S	82407TA	82407R	82407UA	82407U	82407V	
Freq. Range (GHz)	220~325	260~400	325~500	400~600	500~750	750~1100	
Num. of Harmonics	24	18	24	36	48	72	
Freq. Conversion Loss (max, dB)	20	20	30	30	30	45	
Noise Level (dBm/Hz)	-145	-145	-140	-135	-135	-130	
LO Power Range (dBm)	8 to 12	8 to 12	8 to 12	8 to 12	8 to 12	8 to 12	
Max. RF Input Level (dBm)	-10/10	-10/10	-20/5	-20/5	-20/5	-20/5	
Input Port Interface	WR3.4	WR2.8	WR2.2	WR1.2	WR1.5	WR1.0	
Dimensions(W×H×D, mm)	≤120×85×240						

※ Frequency extender modules listed in Tab. 3 are suitable on Ceyear 4051 series spectrum analyzer.

Tab. 4 Mm-wave and THz Power Sensor Specifications

Model	71716	87115N	71717	87115QA	71718	87106A
Freq. Range (GHz)	50 to 75	60 to 90	75 to 110	90 to 140	110 to 170	170 to 220
Power Measurement Range (dBm)	-40 to +20	-60 to +20	-40 to +20	-40 to +20	-35 to +20	-35 to +20
Port SWR	≤1.35	≤1.30	≤1.35	≤1.45	≤1.45	≤1.5
Output Port	WR14.8	WR12.2	WR10	WR8	WR6.5	WR5.1
Dimensions(W×H×D, mm)	≤44×77×220					

Tab. 4 (Cont.) Mm-wave and THz Power Sensor Specifications

Model	87115SA	87106B	87115TA	87108B	87115U
Freq. Range (GHz)	170 to 260	220 to 325	260 to 400	325 to 500	500 to 750
Power Measurement Range (dBm)	-35 to +20	-35 to +20	-35 to +20	-35 to +20	-50 to +20
Port SWR	≤1.5	≤1.5	≤1.5	≤1.8	≤1.8
Output Port	WR4.3	WR3.4	WR2.8	WR2.2	WR1.5
Dimensions(W×H×D, mm)	≤44×77×220				

Tab. 5 Mm-wave and THz Antenna Test System Specifications

Items	Specification	
Freq. Range	40 to 500 GHz	
System Output Power (without power amplifier)	40 to 60GHz	≥+6dBm
	50 to 75GHz	≥+13dBm
	75 to 110GHz	≥+10dBm
	110 to 170GHz	≥+3dBm
	170 to 220GHz	≥-2dBm
	220 to 325GHz	≥-7dBm
Sensitivity	325 to 500GHz	≥-20dBm
	40 to 60GHz	≤-120dBm
	50 to 75GHz	≤-120dBm
	75 to 110GHz	≤-120dBm
	110 to 170GHz	≤-110dBm
	170 to 220GHz	≤-110dBm
Environmental Adaptability	220 to 325GHz	≤-110dBm
	325 to 500GHz	≤-90dBm
	Compliance with GJB3947A-2009 level 4 equipment standard	
	90~240VAC,50/60Hz	
Power Source	90~240VAC,50/60Hz	
Power Consumption	<1500W	
Working Temperature	10 to 40°C	
Frame Structure	1.6m standard test rack (1)	
Dimensions	W×H×D= 600mm×1600mm×800mm	

Tab. 6 Mm-wave and THz RCS Test System Specifications

Items	Specifications
Freq. Range	40 GHz to 500 GHz
Test Method	Monostatic / Bistatic
Polarization	HH, VV, HV, VH
Radiation Power (Peak)	+10dBm (Typ., without amplifier)
Receive Sensitivity	-110dBm (Typ., without amplifier)
Calibration Kits	Metal Ball / Metal Plate / Metal Corner Reflector / Other Comparable Object (with calibrated RCS value)
Power Source	90~240VAC, 50/60Hz
Power Consumption	<3000W
Frame Structure	1.6m standard test rack (without turntable, antenna and other devices)
Dimensions	W × H × D= 600mm × 1600mm × 800mm

Tab. 7 Mm-wave and THz Material Test System Specifications

Items	Specifications
Freq. Range	40 GHz to 500GHz (Depend on VNA and fixture model)
Test Fixtures	Coaxial Air Line Method (include: type N, 3.5mm, 2.4mm)
	Waveguide Cavity Method (suitable for multiple frequency band such as X band, Ku band, Ka band)
	Resonant Cavity Method
	Free Space Method
	Probe Method
Working Modes	Bow Frame Method
	Sweep Frequency Mode
Accuracy	Point Frequency Mode
	Transmission Line Method: ±5% (Typ.) Resonant Cavity Method: 1%
Material Thickness	Transmission Line Method: $\lambda_g/4$ to $\lambda_g/2$ (λ_g : media wavelength)
	Resonant Cavity Method: 0.1mm to 5mm
Test Items	Transmission Line Method: Real & Image Part of Complex Permittivity, Real & Image Part of Complex Permeability, Electrical and magnetic loss angle, Reflectivity
Power Supply	90~240VAC, 50/60Hz

Test System Solutions

mm-wave and THz Vector Network Analysis System

The millimeter-wave terahertz vector network analysis system uses a split structure, with the TEST I/O bus as the system control bus. The measurement of network parameters in different frequency bands can be done by replacing the S-parameter test module in different frequency bands.

System Working Principle

The schematic diagram of the vector network analysis system is shown in Figure 1.

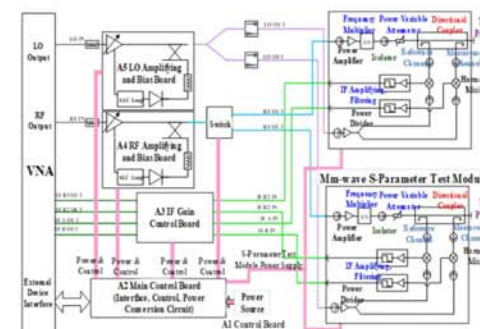

Fig. 1 Mm-wave and THz VNA System Schematic Diagram

The core of the vector network analysis system is the control machine and the mm-wave and THz S-parameter test module. In the control machine, the RF signal from the VNA is amplified by the microwave stabilized amplifying component. The PIN electronic switch is the key component to realize forward and reverse S-parameter testing, when the positive S-parameter test is carried out, the microwave excitation signal is output to the mm-wave and THz S-parameter test module in port 1, the excitation signal pushes the power amplifier and multiplier in the S-parameter test module to produce the mm-wave and THz excitation signal, and this excitation signal is then added to the main circuit via the two-stage cascaded directional coupler in the probe. Wherein, the signal representing the incident wave of the DUT passes through the first directional coupler coupling port, represented by R1, the reflected signal of the DUT passes through the coupling port of the second directional coupler, indicated by A, and the transmission signal of the DUT passes through the coupling port of the S-parameter test module of port 2, represented by B.

The LO signal from the output of the LO source of VNA is divided into four channels by the power divider, and then amplified by the LO amplifier and provided to the harmonic mixer. The mm-wave and THz incident signal R1, the reflected signal A and the transmission signal B are converted to 7.605634MHz IF signals via the harmonic mixing. After the IF signal output by the harmonic mixer is amplified by the control machine and then processed in the VNA, the forward S-parameters of DUT can be calculated: $S_{11}=R1/A$. Similarly, we can get the reverse S-parameter of DUT: $S_{21}=B/R1$. The central control computer can read, print, and store test results.

System Components

The system is mainly composed of vector network analyzer, control machine, Millimeter Wave and Terahertz S parameter test module and waveguide calibration kit, as shown in Figure 2.



Fig. 2b Mm-wave and THz VNA System (Type-I: based on 4 ports VNA)



Fig. 2b Mm-wave and THz VNA System (Type-II: based on 2 ports VNA and controller)

Tab. 8 Mm-wave and THz VNA System Components List

Model	Name	Main Specification	Num.	Remark (s)
3672B	Vector Network Analyzer	10MHz to 26.5GHz	1	-
3672C		10MHz to 43.5GHz		
3672D		10MHz to 50GHz		
3672E		10MHz to 67GHz		
3640A	Frequency Extension Controller	-	1	-
3643K	S-Parameter Test Module	40GHz to 60GHz	1 pair	Standard Rectangular Waveguide Test Port Optional Frequency Bands
3643NA		50GHz to 75GHz	1 pair	
3643N		60GHz to 90GHz	1 pair	
3643P		75GHz to 110GHz	1 pair	
3643QA		90GHz to 140GHz	1 pair	
3643Q		110GHz to 170GHz	1 pair	
3643SA		140GHz to 220GHz	1 pair	
3643R		170GHz to 260GHz	1 pair	
3643S		220GHz to 325GHz	1 pair	
3643TA		260GHz to 400GHz	1 pair	
3649B		325GHz to 500GHz	1 pair	
3643U		500GHz to 750GHz	1 pair	
32121K	-	40GHz to 60GHz	1 set	Select According to Mm-wave and THz Module
32156		50GHz to 75GHz	1 set	
32155N		60GHz to 90GHz	1 set	
32141		75GHz to 110GHz	1 set	
32155Q		90GHz to 140GHz	1 set	
32155		110GHz to 170GHz	1 set	

Model	Name	Main Specification	Num.	Remark (s)
20301	-	170GHz to 220GHz	1 set	Select According to Mm-wave and THz Module
32155S		170GHz to 260GHz	1 set	
20302		220GHz to 325GHz	1 set	
32155T		260GHz to 400GHz	1 set	
20301T		325GHz to 500GHz	1 set	
52155U	-	500GHz to 750GHz	1 set	-
-	Cables	-	1 set	See Details in Fig. 9

Auxiliary cables required in mm-wave and THz VNA system are listed in Tab. 9:

Tab. 9 Mm-wave and THz VNA System Cable List

No.	Application	Length (m)	Connector	Num.	Remark(s)
Microwave Cable					
A1	VNA: RF OUT ↔ Freq. Ext. Controller: RF IN	0.6/0.8/1	3.5mm/3.5mm-JJ	1	Low Loss Cable, Optional Length
A2	VNA: LO OUT ↔ Freq. Ext. Controller: LO IN	0.6/0.8/1	3.5mm/3.5mm-JJ	1	Low Loss Cable, Optional Length
A3/A4	Freq. Ext. Controller: RF OUT ↔ S-Parameter Test Module: RF IN	1.2/1.5/2	3.5mm/3.5mm-JJ	2	Low Loss Cable, Optional Length
A5/A6	Freq. Ext. Controller: LO OUT ↔ S-Parameter Test Module: LO IN	1.2/1.5/2	3.5mm/3.5mm-JJ	2	Low Loss Cable, Optional Length
IF Cable					
C1	Freq. Ext. Controller: IF OUT ↔ VNA: IF IN	0.6/0.8/1	SMA/SMA	4	Optional Length
C2	S-Parameter Test Module: IF OUT ↔ Freq. Ext. Controller: IF IN	1.2/1.5/2	SMA/SMA	4	Optional Length
Communication & Power Source Cable					
D1	VNA: External Test Device Interface ↔ Freq. Ext. Controller: External Test Device Interface	1	PCL-10125	1	Communication Cable
D2	Freq. Ext. Controller: Power OUT ↔ S-Parameter Test Module: Power IN	1.2/1.5/2	Round Connection Cable	2	Power Source Cable, Optional Length

System Software Function

Vector network analysis system software is mainly used to completes the system configuration and perform data collection, storage, printing and other functions.

System Structure Design

The use of the "control machine plus dual module" form is a leap forward in the development of the vector network analyzer millimeter wave-waveguide system, this structural form not only improves the technical specifications of the whole system, but also simplifies the connection process of the test, and can simultaneously measure the forward and reverse S parameters of the device under test.

The control machine uses a standard profile frame and uses the national standard chassis size. In addition to the stable semi-rigid cable connection between the coaxial connectors, microwave components and chassis are rigidly connected and inelastic contact, making them robust and reliable. Printed circuit boards have corresponding shielding boxes and a good grounding path with the chassis. The position, electromagnetic shielding and cooling of microwave mm-wave and THz components are considered in the structural design process.

Ceyear mm-wave and THz S-parameter test module uses a common chassis structure and enclosure appearance in each band. The unique octagonal shape structure is beautiful and generous, and the scientific distribution of thermal holes ensures the thermal effect and improves the reliability of the product. For easy measurement, we have designed an adjustable sole foot to connect a variety of waveguide subjects flexibly and easily by adjusting the height of the module output port. The inside of the module uses a joint bracket to connect the components together, solid and reliable, can resist a variety of vibration, shock. The modules are compact and portable, perfect for a wide range of applications.

Mm-wave and THz Signal Generation System

The mm-wave and THz signal generation system is shown in Figure 3 and consists of a signal generator and a source extender module. The signal generator controls the mm-wave and THz source extender module by special control cable to realize the identification and setting of information such as the frequency band. The RF signal is output via RF cable to the input of source extender module. The DC power supply required for the source extender module is supplied by the adapter.



Fig. 3 Mm-wave and THz Source Extender and Signal Generation System

System Working Principle

The schematic diagram of source extender module is shown in Fig.4.

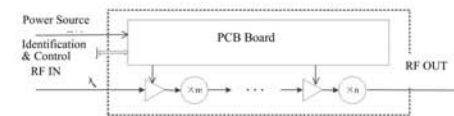

Fig. 4(a) Schematic Diagram – Standard Source Extender Module

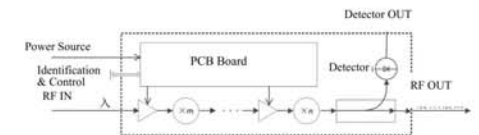

Fig. 4(b) Schematic Diagram – Source Extender Module with Amplitude Stabilization Option

Ceyear source extender module uses technologies such as mm-wave and THz power amplification technology and frequency multiplication based on Schottky diodes. Low-band signals generated by existing microwave signal synthesis sources are multi-stage multiplied, thus meeting the power and frequency requirements. The DC power supply provides bias voltage to the amplifier via PCB board inside the source extender module. The PCB board also stores basic information such as working band to realize the amplitude control and automatic identification functions of the source extender module by Ceyear signal source.

System Components

Ceyear mm-wave and THz signal generation system is mainly composed of 1464/1465 series signal generator and source extender module. The list of instruments required for this system is shown in Tab. 10.

Tab. 10 Mm-wave and THz Signal Generation System Components

Model	Name	Specification	Num.	Remark(s)
1465D (-V)	Signal Generator	100kHz to 20GHz	1	With Frequency Extension Function
1465F (-V)	Signal Generator	100kHz to 40GHz		
1465H (-V)	Signal Generator	100kHz to 50GHz		
1465L (-V)	Signal Generator	100kHz to 67GHz		
82406	Mm-wave and Thz Source Extender Module	50GHz to 75GHz	1	Standard Rectangular Waveguide Test Port Optional Frequency Bands
82401N		60GHz to 90GHz	1	
82406A		75GHz to 100GHz	1	
82401QA		90GHz to 140GHz	1	
82406B		110GHz to 170GHz	1	
82406C		170GHz to 220GHz	1	
82401SA		170GHz to 260GHz	1	
82406D		220GHz to 325GHz	1	
82401TA		260GHz to 400GHz	1	
82406E		325GHz to 500GHz	1	
82401U	500GHz to 750GHz	1		
82401V	-	750 GHz to 1100GHz	1	
-	RF Connection Cable	-	1	3.5mm-JJ-1.2M
-	2.4mm to 3.5mm transistor	-	1	Select According to Signal Generator Model: 1465D (-V): 3.5mm(m) 1465F (-V): 2.4mm(m) 1465H (-V): 1.85mm(m) 1465L (-V): 1.85mm(m) THz Source Extender Module: 3.5mm
-	1.85mm to 3.5mm transistor	-		
-	Software	-	1	Synthesis Source Control
-	Power Adapter	-	1	15V, Standard
-	Automatic Identification Cable	-	1	Standard

System Structure Design

Ceyear mm-wave and THz source extender module uses a common chassis structure and enclosure appearance in each band. The unique octagonal shape structure is beautiful and generous, and the scientific distribution of thermal holes ensures the thermal effect and improves the reliability of the product. For easy measurement, we have designed an adjustable sole foot to connect a variety of waveguide subjects flexibly and easily by adjusting the height of the module output port. The inside of the module uses a joint bracket to connect the components together, solid and reliable, can resist a variety of vibration, shock. The modules are compact and portable, perfect for a wide range of applications.

System Compatibility

The frequency source extender modules can be compatible with signal generators of other companies, but the frequency of the signal generator should meet the driving frequency requirements of the frequency multiplier source module listed in Table 2, and the power of the signal generator needs to be above +5dBm.

Note: When used with other company's signal generators, for the convenience of testing, it should be ensured that the frequency multiplication factor of the signal generator can be set to the corresponding frequency multiplication times of the frequency multiplication source module. For example: 82401V is 72 times frequency multiplication, the frequency multiplication factor should be set to 72 on the signal generator;

When used with signal generators of other companies, the amplitude stabilization option cannot be added.

Mm-wave and THz Spectrum Analysis System



Fig. 5 Mm-wave and THz Spectrum Analysis System Components

Ceyear mm-wave and THz spectrum analysis system, shown in Fig. 5, is composed of a spectrum analyzer and a frequency extender module, which can be applied to test and analyze signal from 50GHz to 750GHz by replacing the module in different frequency bands.

System Working Principle

The schematic diagram of the system is shown in Figure 6. The LO signal required for the frequency extender module is generated by the spectrum analyzer host via RF cable, and the IF signal from frequency extender module is input and then processed by spectrum analyzer via cable. Power supply and communication between module and signal generator are realized via a USB cable.

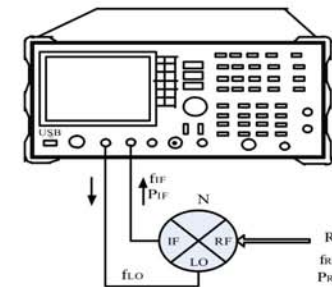

Fig. 6 Mm-wave and THz Spectrum Analysis System Schematic Diagram

When the frequency extender module is connected to the spectrum analyzer using a USB cable, spectrum analyzer will automatically recognize the frequency extender module. The operating frequency range of spectrum analyzer will be automatically set to the corresponding frequency range of the frequency extender module, and the variable frequency loss data stored in the module will be automatically read and configured in spectrum analyzer to accurately measure the power of the signal under test. This eliminates the cumbersome operation process such as manually selecting the frequency extender module working band and manually entering variable frequency loss data to the spectrum analyzer point by point, and improves the test efficiency.

Since there is no pre-selected filter above 50GHz to preselect signals, spectrum analyzers typically extend the spectrum by harmonic mixing. In the absence of a millimeter-wave tracking pre-selector, even if the measured signal is a single spectral line, many spectral lines will be displayed on the spectrum analyzer's display, making it extremely difficult for the operator to identify the true signal frequency under test. In this case, 4051's 'Signal Recognition' function can automatically eliminate fake spectral lines. The spectrum analyzer will only display real-life signal spectral lines, which greatly facilitates spectral measurement.

System Components

The system is mainly composed of a synthetic spectrum analyzer and a frequency extender module. The list of instruments required for this system are listed in Tab. 11.

Tab. 11 Mm-wave and THz Spectrum Analysis System Components

Model	Name	Specification	Num.	Remark(s)
4051B	Spectrum Analyzer	3Hz to 9GHz	-	-
4051C		3Hz to 13.2GHz		-
4051D		3Hz to 18GHz		-
4051E		3Hz to 26.5GHz		-
4051F		3Hz to 40GHz		-
4051G		3Hz to 45GHz		-
4051H		3Hz to 50GHz		-
4051L		3Hz to 67GHz		-
82407	Spectrum Analyzer Frequency Extender Module	50GHz to 75GHz	1	Standard Rectangular Waveguide Test Port Optional Frequency Bands
82407NB		60GHz to 90GHz	1	
82407NC		60GHz to 90GHz	1	
82407A		75GHz to 100GHz	1	
82407QA		90GHz to 140GHz	1	
82407B		110GHz to 170GHz	1	
82407C		170GHz to 220GHz	1	
82407SA		170GHz to 260GHz	1	
82407D		220GHz to 325GHz	1	
82407TA		260GHz to 400GHz	1	
82407R	325GHz to 500GHz	1		
82407U	500GHz to 750GHz	1		
-	RF Cable	-	2	2.4mm-JJ
-	USB Cable	-	1	N/3.5mm-JJ
-	2.4mm (f) to 3.5mm (m) Transistor	-	1	Suitable for 82407NC/SA/TA/R/U
-	Software	-	1	Spectrum Analyzer Control

Mm-wave and THz Power Measurement System



Fig. 7 Ceyear Mm-wave and THz Power Meter and Power Sensor

The mm-wave and THz power test system is shown in Figure 7. The "split" method of one power meter and one mm-wave and THz Power Sensor is implemented. The Power Sensor is software controlled by power meter and perform data transmission via cables. Power detection and measurement from 50GHz to 750GHz can be achieved in the band by replacing different mm-wave and THz Power Sensors. The minimum detection power can reach -60dBm.

System Working Principle

The mm-wave and THz Power Sensor adopts the power detection method of low potential base diode detection, which has the advantages of fast test speed, low temperature influence and high stability compared with thermocouple detection method.

The schematic diagram is shown in Fig. 8.

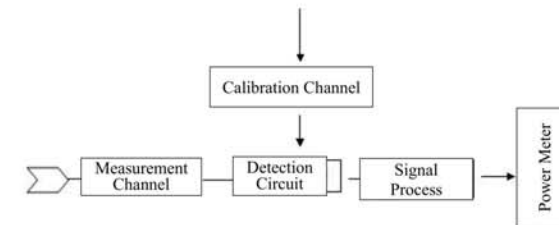

Fig. 8 Mm-wave and THz Power Sensor Schematic Diagram

System Components

Ceyear mm-wave and THz power measurement system is mainly composed of the power meter and mm-wave and THz Power Sensor. The list of instruments required for this system is shown in Tab. 12.

Tab. 12 Mm-wave and THz Power Measurement System Components

Model	Name	Specification	Num.	Remark(s)
4051B	Spectrum Analyzer	3Hz to 9GHz	-	-
4051C		3Hz to 13.2GHz		-
4051D		3Hz to 18GHz		-
4051E		3Hz to 26.5GHz		-
4051F		3Hz to 40GHz		-
4051G		3Hz to 45GHz		-
4051H		3Hz to 50GHz		-
4051L		3Hz to 67GHz		-
82407	Spectrum Analyzer Frequency Extender Module	50GHz to 75GHz	1	Standard Rectangular Waveguide Test Port Optional Frequency Bands
82407NB		60GHz to 90GHz	1	
82407NC		60GHz to 90GHz	1	
82407A		75GHz to 100GHz	1	
82407QA		90GHz to 140GHz	1	
82407B		110GHz to 170GHz	1	
82407C		170GHz to 220GHz	1	
82407SA		170GHz to 260GHz	1	
82407D		220GHz to 325GHz	1	
82407TA		260GHz to 400GHz	1	
82407R	325GHz to 500GHz	1		
82407U	500GHz to 750GHz	1		
-	RF Cable	-	2	2.4mm-JJ
-	USB Cable	-	1	N/3.5mm-JJ
-	2.4mm (f) to 3.5mm (m) Transistor	-	1	Suitable for 82407NC/SA/TA/R/U
-	Software	-	1	Spectrum Analyzer Control

Mm-wave and THz Antenna Test System



Fig. 9 Ceyear Mm-wave and THz Antenna Test System

Ceyear mm-wave and THz antenna test system is shown in Figure 9. The system uses high-performance modular microwave millimeter wave test equipment, and seamless coverage of the full band up to 500GHz is achieved through the system form of the microwave platform plus mm-wave frequency extender module. According to the different test requirements of the user, the antenna performance in corresponding frequency bands can be tested flexibly by configuring different millimeter wave modules.

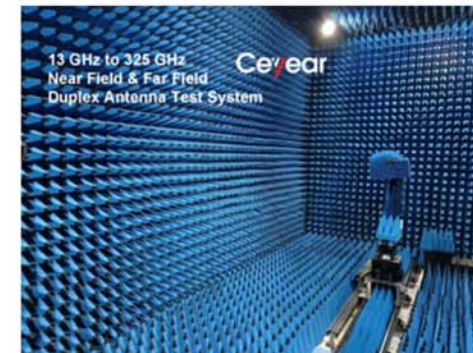

Fig. 10 THz Antenna Test Anechoic Chamber

System Working Principle

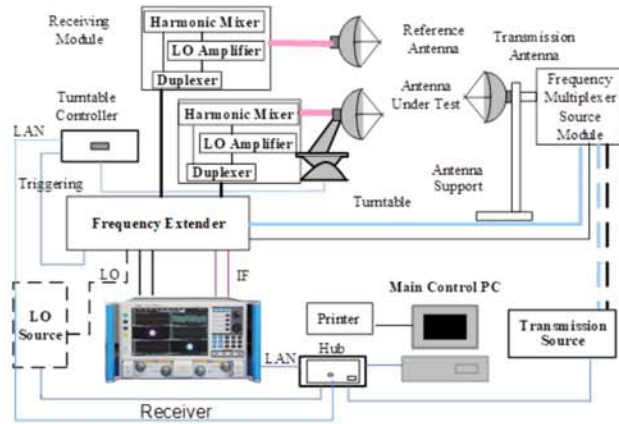

Fig. 11 Mm-wave and THz Antenna Test System Schematic Diagram

Ceyear mm-wave and THz antenna test system schematic is shown in Figure 11. This is a typical far-field testing scheme, the system is divided into two parts and placed in the interval of a certain relative distance. The AUT is mounted on the antenna turntable. In the system, the master computer is the core of coordinated control. Under its control, the RF and LO signal generated by the coaxial vector network analyzer are sent to the frequency extender module. In the case of an external source, these two signals can also be generated by the signal source. In the frequency extender module, the RF signal is output by the source extender interface after stabilization, amplification and matching, and the LO signal is output by dividing, amplifying and matching.

The mm-wave source extension interface is equipped on the frequency extender module. Coordinated with the mm-wave and THz source extender module in different frequency bands, the millimeter wave signal of the corresponding frequency band can be generated and radiated by the transmitting antenna. The AUT and reference antenna receive the mm-wave RF signal and send it to the mm-wave receiving module, while the LO signal will also be sent to the receiving module, pass through the duplexer and amplifier, finally arrive at the LO port of harmonic mixer. Thus, we will obtain the required IF signal by harmonic mixing. The IF signal output by duplex in the frequency extender module will be amplified and then sent to the external IF input port of the vector network analyzer for further analysis and process. Finally, the VNA obtains amplitude and phase information of the signal. The master computer obtains the test data through the bus interface, coordinates the rotation of the control turntable to obtain the measurement data of the different orientations of the AUT, and completes the test of the antenna direction map characteristics.

For near field testing, the system instrument equipment is the same. User just need to configure the near-field scanner and other motion devices instead of the far field test turntable, then perform test in the near-field area of the AUT. The test data will be analyzed and processed through the software. Finally, we can get the performance parameters of the AUT.

System Components

The instruments used in the antenna test system are listed in Tab. 13.

Tab. 13 Mm-wave and THz Antenna Test System Components

Model	Name	Specification	Num.	Remark(s)
3672C	Vector Network Analyzer	10MHz to 43.5GHz	1	-
3635A	LO and IF Distribution Unit	10MHz to 50GHz		-
1465F	Signal Generator	100kHz~40GHz	1	Transmitter Source
82719G	Antenna Test System Receiver Module	40GHz to 60GHz	1 pair	Standard Rectangular Waveguide Test Port
82719NA		50GHz to 75GHz	1 pair	
82719P		75GHz to 110GHz	1 pair	
82719Q		110GHz to 170GHz	1 pair	
82719R		170GHz to 220GHz	1 pair	
82719S		220GHz to 325GHz	1 pair	
82719T		325GHz to 500GHz	1 pair	
82718G	Antenna Test System Transmitter Module	40GHz to 60GHz	1	Standard Rectangular Waveguide Test Port
82718NA		50GHz to 75GHz	1	
82718P		75GHz to 110GHz	1	
82718Q		110GHz to 170GHz	1	
82718R		170GHz to 220GHz	1	
82718S		220GHz to 325GHz	1	
82718T		325GHz to 500GHz	1	
-	Turntable/Scan Rack	Customization	1	-
-	T/R Antenna	Standard WR Bands	1 pair each	-
-	Control PC & Printer	-	1	-
-	System Software	-	1	-
-	Connection Cable	-	1	-
88905B	1.6m Test Rack	-	1	-

Mm-wave and THz RCS Test System

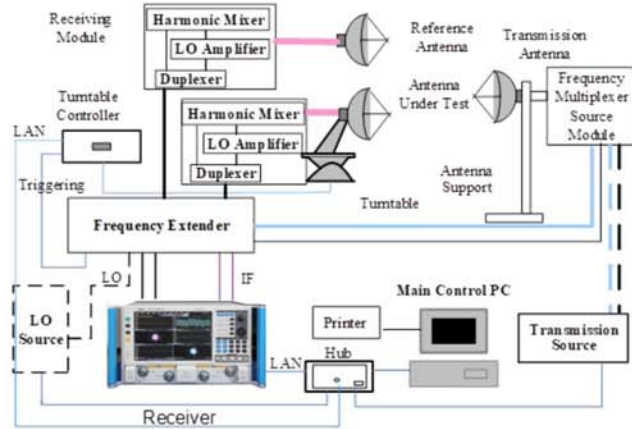

Fig. 12 Mm-wave and THz RCS Test System Schematic Diagram

Ceyear mm-wave and THz RCS test system is shown in Figure 12. The system composition, mm-wave signal generation/receiving methods are identical to antenna testing system, but there are differences in instrument placement and subsequent signal processing. For far-field RCS tests, the target subject is usually placed at the far end of the transceiver antenna, and the distance should meet the far-field conditions. The millimeter-wave signal generated by the system radiates through the transmitting antenna and scatters through the target subject. The scattering signal is received by the receiving antenna and processed to obtain the amplitude/phase data of the target echo signal. By controlling the turntable rotation and performing back-end signal processing, the system can obtain the RCS characteristic value of the target subject at different angles, and can achieve two-dimensional imaging of the distribution of the target scattering point.

System Components are listed in Tab. 14.

Tab.14 Mm-wave and THz RCS Test System Components

Model	Name	Specification	Num.	Remark(s)
3672C	Vector Network Analyzer	10MHz to 43.5GHz	1	-
3635A	LO and IF Distribution Unit	1GHz to 20GHz	1	-
82718G	RCS System Transmitter Module	40GHz to 60GHz	1	Standard Rectangular Waveguide Test Port
82718NA		50GHz to 75GHz	1	
82718P		75GHz to 110GHz	1	
82718Q		110GHz to 170GHz	1	
82718R		170GHz to 220GHz	1	
82718S		220GHz to 325GHz	1	
82718T		325GHz to 500GHz	1	
82719G	RCS System Receiver Module	40GHz to 60GHz	1	Standard Rectangular Waveguide Test Port
82719NA		50GHz to 75GHz	1	
82719P		75GHz to 110GHz	1	
82719Q		110GHz to 170GHz	1	
82719R		170GHz to 220GHz	1	
82719S		220GHz to 325GHz	1	
82719T		325GHz to 500GHz	1	
-	Turntable/Scan Rack	Customization	1	-
-	T/R Antenna	Standard WR Bands	1 pair each	-
-	Control PC & Printer	-	1	-
-	System Software	-	1	-
-	Connection Cables	-	1	-
-	1.6m Test Rack	-	1	-
88905B	Turntable/Scan Rack	-	1	-

Mm-wave and THz Material Test System



Fig. 13 Mm-wave and THz Material Test System

Ceyear mm-wave and THz material test system is shown in Fig. 13. Based on the mm-wave and THz vector network analyzer, the system can perform electromagnetic parameter testing of various types of media materials by configuring the corresponding test fixtures. Ceyear material test system can realize the complex permittivity (ϵ), complex permeability (μ) test of the material, which meet the testing needs of mm-wave stealth material, mm-wave component media material and other fields.

The schematic diagram of Ceyear mm-wave and THz material test system is shown in Fig. 13. The system consists of vector network analyzer, master computer, series test fixture, calibration kits and so on. Under the coordinated control of the master computer, the vector network analyzer enables the generation and analysis of mm-wave and THz signal, and the serialized material test fixture transmits the signal generated by VNA onto the material under test and collects the response characteristics back to the VNA. The material test software obtains the electromagnetic parameters of the material by analyzing the S-parameters. Depending on specific test parameters and indicator requirements, the system provides a wide selection range of test fixtures such as Bow frame, coaxial air-line, waveguide cavity, probe, free space, etc.

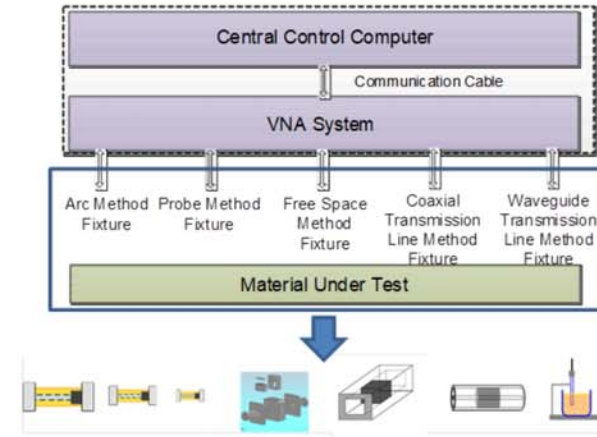

Fig. 13 Mm-wave and THz Material Test System Schematic Diagram

Ceyear material test system components are listed in Tab. 15.

Tab. 15 Mm-wave and THz Material Test System Components

Model	Name	Specification	Num.	Remark(s)
3672 series	Vector Network Analysis System	40GHz to 500GHz	1	1. 3672B/C/D/E VNA 2. 3640A Frequency Extension Controller (For 2-Port VNA) 3. 364X Frequency Extender Module
9809-001	Waveguide Transmission Line Testing Suit	Banded from 40GHz to 500GHz	1	
9809-002	Resonant Cavity Testing Suit	Point Frequency, Customize	1	-
9809-003	Free Space Testing Suit	40GHz to 500GHz	1	-
9809-005	Bow Frame Testing Suit	40GHz to 500GHz	1	-
	Control PC & Printer	-	1	-
9809	System Software	-	1	-
	Connection Cables	-	1	-
88905B	1.6m Test Rack	-	1	-